



PUMA™ VTOL KIT

AeroVironment's Puma™ VTOL (vertical takeoff and landing) Kit is designed for plug-and-play integration into Puma AE small unmanned aircraft systems (SUAS). The VTOL Kit expands the operational capabilities of the combat-proven Puma systems in urban environments as no runway or large open space is required for launch and recovery, allowing operators to launch anywhere, anytime.

Available as an add-on option for new Puma 2 AE and Puma 3 AE system orders and as a retrofit kit, existing Puma AE customers can upgrade fielded systems with minimal modifications to the aircraft's airframe and with simple software upgrades. Removable, the kit will allow operators to transition between fixed-wing and VTOL to suit varying mission needs with a single aircraft.

Kizilirmak Mah. 1446. Cad. No: 12/18
Cukurambar 06530 Cankaya, Ankara / TURKEY
Tel : +90 (312) 284 30 12 (PBX)
Fax : +90 (312) 284 30 14
altoy@altoy.com.tr www.altoy.com.tr



DISTINCTIONS



»» LAUNCH AND RECOVERY

Vertical Takeoff and Landing (VTOL)



»» COMPATIBILITY

Puma™ 2 AE & Puma™ 3 AE



»» SETUP TIME

Under 5 min

SPECIFICATIONS

TOTAL PAYLOAD CAPACITY	Mantis i45 or Mantis i45 N (2 lb) Up to 2 lb of additional payload*
ENDURANCE	1.5 hr with PS2500 battery 1.2 hr with Puma™ Smart Battery
OPERATING ALTITUDE	Launch & recovery 7K ft Density Altitude (DA) Max. flight altitude 10K ft DA
WEIGHT	VTOL Kit: 7 lb (3.2 kg)
MAX WIND RESISTANCE	15 kts
ENVIRONMENTAL RATING	All-weather (no water landing)

*Upgraded Puma motor required to carry secondary payload in universal Transit Bay

PATH TO UPGRADE

- Puma™ avionics software update required (fully backwards compatible)
- INS/GPS software update required (fully backwards compatible)
- Upgraded Puma™ motor recommended
- Crysalis™ GCS required

KIT COMPONENTS

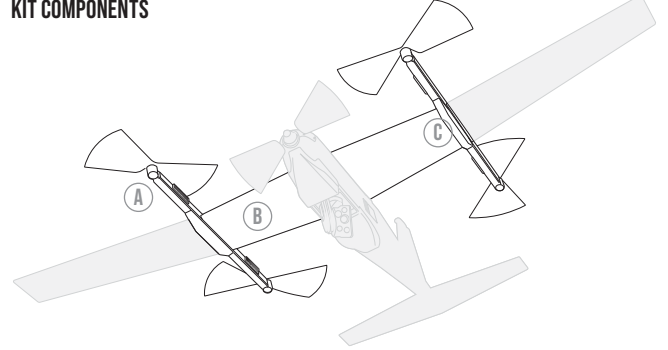

(A) VTOL boom assemblies (2)

(B) Pre-wired center wing (1)

(C) Batteries, removable & rechargeable (1 per boom)

Avionics module (1) - *Not shown*

Fastening hardware (1) - *Not shown*

KEY FEATURES

- »» Automated one-button launch & recovery in confined environments
- »» Highly reliable automated takeoff & landing with or without GPS**
- »» Single-case packout maintaining a minimal logistical footprint
- »» Maintains Puma™ all-weather rating (excludes water landing)
- »» Available as an add-on or retrofit kit

**Landing precision may vary in the absence of GPS

